

Range
Multitruck

MEGGA



Chassis Cab

Technical Specifications

	Combustion engine	Electric Motor
	Diesel 600	8 or 12 Batteries
Engine	Kubota	General Electric 48V
Position	Transverse central	Transverse central
Capacity (cm3)	599	Electric motor with separate excitation and electronic variator
Max. power (kW CEE)	11.2	4
Torque (Nm at rpm)	34 at 2200	-
Max. laden engine speed (rpm)	3600	-
Fuel supply	Indirect injection	Direct current
Alternator	500 W	-
Service battery	12V 40 Ah	12V 40 Ah
Traction battery		8 or 12 lead gel batteries (maintenance free)
Charger	-	220V 16A
Transmission	Automatic by variator	Automatic by variator
Steering	rack and pinion	rack and pinion
Braking	Dual circuit with limiter through load sensing valve Low level wear indicators Front disk diameter 240mm Rear drum diameter 160mm Mechanically operated parking brake on rear axle	
Suspension	Front: Independent MacPherson Strutt type coil springs Independent rear suspension with coil springs	
Tyres	145/70R13	145/70R13
Tank	24 L	-
Performances:		
Max. speed (mph)	approx. 50	approx. 30
Autonomy (km)	approx. 530	8 battery: 25-35 miles / 12 battery: 40-60 miles
Consumption (L/100km)	approx. 4.5	

Chassis Cab

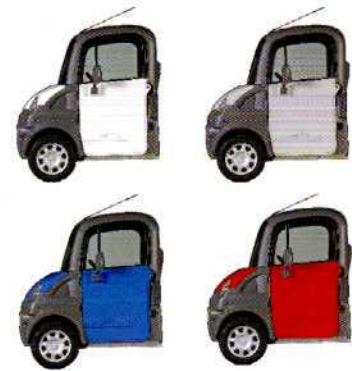
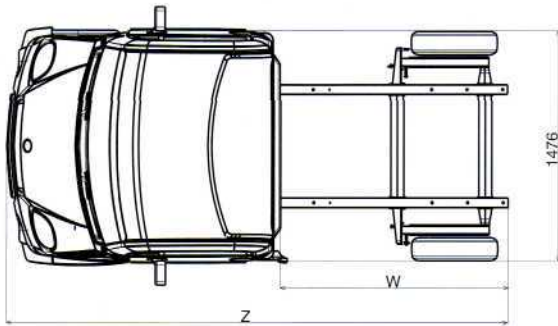
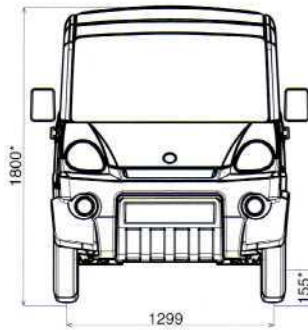
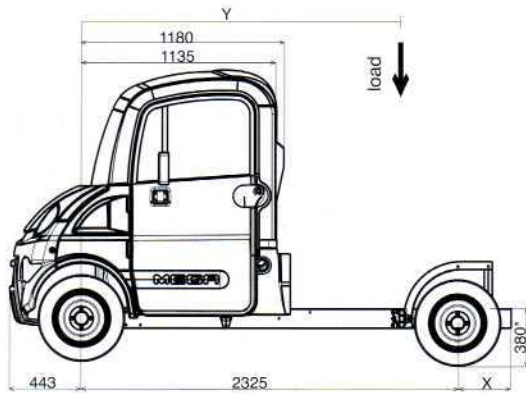

4 colour choice

Dimensions (mm)

Wheel base	2325
Min. overall length (Z)	3102
Max. overall length (Z)	3753
Overall width (excluding rear view mirrors)	1476
Overall height	1800*
Max. load length (W)	2130
Min. load length (W)	1479
Max. load width	1530
Max. overall load height	2500
Unladen chassis height	380* (480* in electric version)
Front ground clearance	155*
Rear ground clearance	200*
Max. rear overhang	985
Min. rear overhang	334
Limit position of centre of gravity with respect to front axle axis (Y)	min. 1930 max. 2060
Front track	1299
Rear track	1273

* unladen vehicle ± 20mm

MOTOR

Weight (kg)	MOTOR		
	Combustion Diesel 600	Electric Electric 8 Battery	Electric Electric 12 Battery
Weight in unladen condition	420	590	700
Unladen weight distribution			
FRONT	290	340	390
REAR	130	250	310
Pay load	530	530	420
Total authorised laden weight	950	1120	1120
Max. tolerated load on axle			
FRONT	475	520	520
REAR	690	690	690

Standard Equipment

- ▶ Steering lock
- ▶ 3-speed motor wiper
- ▶ Digital dashboard display
- ▶ Electrical windscreen washer
- ▶ Hazard lights
- ▶ Inertia safety belts
- ▶ Rearview mirror
- ▶ Left and right wing mirrors
- ▶ Tinted glass
- ▶ 3-speed heater with defrost
- ▶ Engine soundproofing
- ▶ "Lights on" warning buzzer
- ▶ Interior lighting controlled by door switch
- ▶ Ashtray and cigarette lighter
- ▶ Centre storage pocket
- ▶ Pre-wired for radio
- ▶ Sun visor with passenger side make-up mirror
- ▶ Lockable fuel tank cap
- ▶ Rubber floor mats
- ▶ Wheel trims
- ▶ Economy and standard drive mode (electric)

Optional Equipment

- ▶ More options are available
(see individual specification pages)

